

MULTILOGGER

Celibrated universal 16-channel datalogger with Ethernet interface

PORTABLE



STATIONARY



- **On-line monitoring**
- **Recording of Data**
- **Alarm Warnings**
 - Temperature
 - Humidity
 - Barometric pressure
 - CO₂
 - Sensors with output 0-20 mA, 0-10V
 - Two-state inputs
 - Pulse counter



Multilogger

The device is designed for measurement and recording of physical and electrical quantities with adjustable recording intervals from 1 second to 24 hours.

4 inputs

All models have 4 input connectors for external probes or signals. These may be supplemented by an internal atmospheric pressure transducer and / or CO₂ sensor.

Evaluation of up to 16 variables

Up to 16 variables may be calculated from the four connected probes / sensors. (This is the sum of the measured and calculated values). The calculated values can be:

- a further expression of moisture (dew point temperature, absolute humidity, specific humidity, mixing ratio, specific enthalpy)
- the result of inter-channel conversions (eg. the difference of two connected temperature probes)

Alarm limits

It is possible to set two independent alarm limits for each channel (ie. measured or calculated value) which can be configured either as an upper and lower limit or two limits exceeding in a consistent direction. Alarm signalization can be acoustic (built-in beeper), optical (3 LEDs), alarm output or sending an e-mail alert.

Power supply

Power is provided from an external AC adapter, and operation of the device (except Ethernet interface) is backed up by replaceable batteries. The device can be used permanently installed or as portable device with the option to charge batteries directly using the AC adapter or using standard alkaline batteries size AA. Battery life is several months.

Ethernet interface allows you to:

- send an email when an alarm state starts or ends
- use DATALINK: display current values or download values from device memory to your PC
- view current measured values using your web browser
- third-party applications to read the actual measured values using universal protocols SNMPv1 and XML
- send data to COMET DATABASE software which contains many useful tools for data analysis - graphs, tables, statistics, etc.

Types of connectors



Supported probes and input signals

Temperature probes Pt1000 (serie xxx/M)	Temperature/relative humidity probes with digital output (serie DIGI)	The probes are interchangeable without calibration to a specific device and regardless of the length of the cable. The length of the cable can be 1, 2, 5, 10, 15 metres.
Thermocouple K, J, S, B, T, N	Sensors with bipolar output voltage and a range of - 60 to + 140 mV (heat flux sensors, etc.)	
Devices with two-state output (monitoring of machine run, door open/close, etc.)	Device with pulse output (gas and water meters, counter pieces on a production line, etc.)	Sensors of physical quantities with voltage output 0-10 V (0-5 V, 0-1 V) or current output 0-20 mA (4-20 mA)

Measured values can be directly recalculated in the device by linear conversion for transfers, for example from 4-20 mA current loop to a specific temperature range.

Voltage or current output sensors must be powered from an external source .

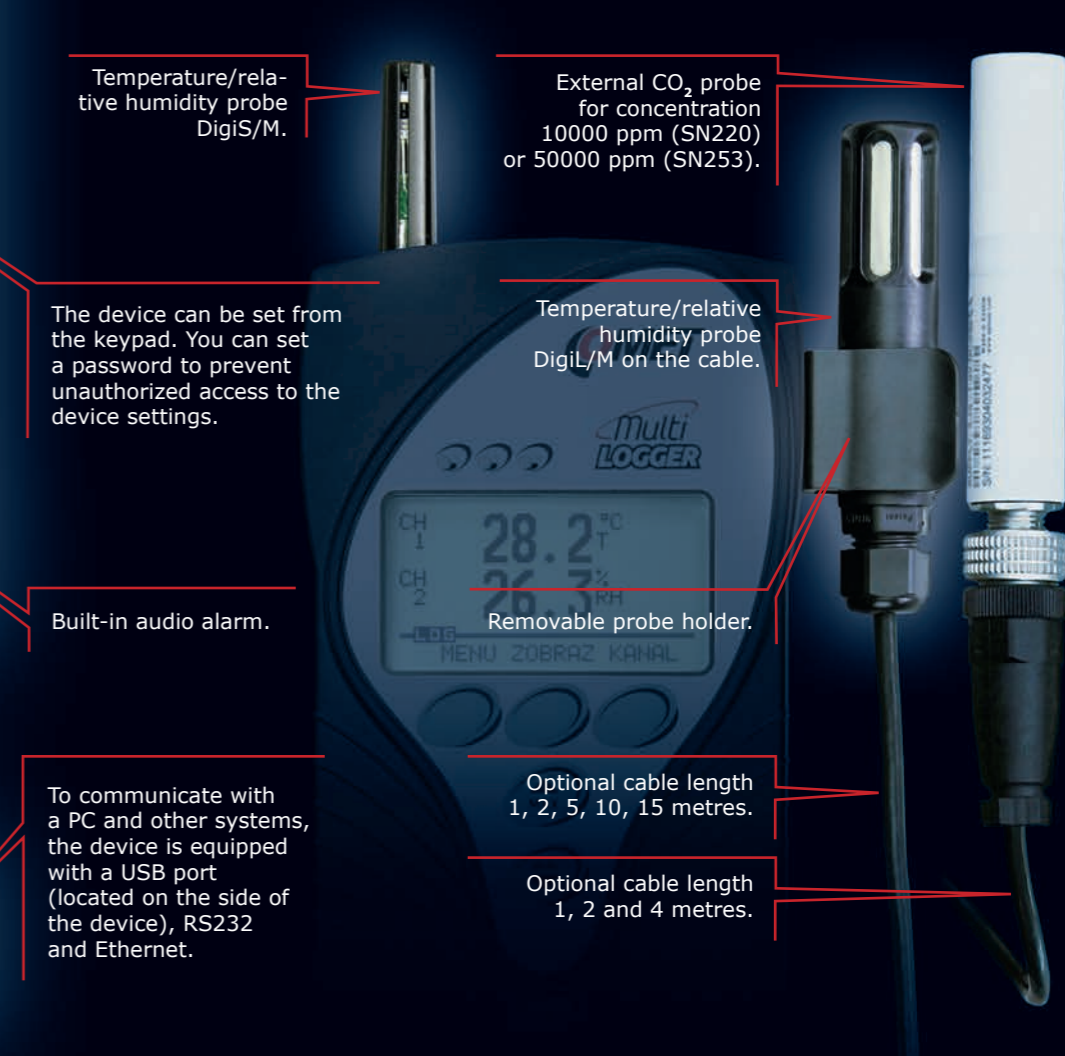

Multilogger

The device is designed for measurement and recording of physical and electrical quantities with adjustable recording intervals from 1 second to 24 hours.

4 inputs

All models have 4 input connectors for external probes or signals. These may be supplemented by an internal atmospheric pressure transducer and / or CO₂ sensor.

Evaluation of up to 16 variables

Up to 16 variables may be calculated from the four connected probes / sensors. (This is the sum of the measured and calculated values). The calculated values can be:

- a further expression of moisture (dew point temperature, absolute humidity, specific humidity, mixing ratio, specific enthalpy)
- the result of inter-channel conversions (eg. the difference of two connected temperature probes)

Alarm limits

It is possible to set two independent alarm limits for each channel (ie. measured or calculated value) which can be configured either as an upper and lower limit or two limits exceeding in a consistent direction. Alarm signalization can be acoustic (built-in beeper), optical (3 LEDs), alarm output or sending an e-mail alert.

Power supply

Power is provided from an external AC adapter, and operation of the device (except Ethernet interface) is backed up by replaceable batteries. The device can be used permanently installed or as portable device with the option to charge batteries directly using the AC adapter or using standard alkaline batteries size AA. Battery life is several months.

Ethernet interface allows you to:

- send an email when an alarm state starts or ends
- use **DATALINK**: display current values or download values from device memory to your PC
- view current measured values using your web browser
- third-party applications to read the actual measured values using universal protocols SNMPv1 and XML
- send data to **COMET DATABASE** software which contains many useful tools for data analysis - graphs, tables, statistics, etc.

Types of connectors

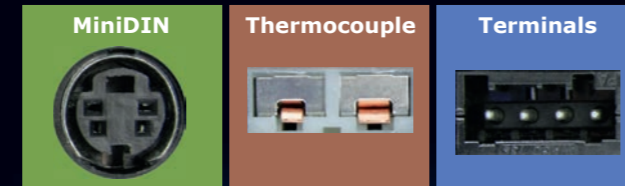

Nine models of MULTILOGGER

Model	Input 1	Input 2	Input 3	Input 4	Internal sensor
M1140	MiniDIN	MiniDIN	MiniDIN	MiniDIN	
M1200	Thermocouple	Thermocouple	Thermocouple	Thermocouple	
M1200*	Termočlánek	Termočlánek	Thermocouple	Thermocouple	
M1220	MiniDIN	MiniDIN	Thermocouple	Thermocouple	
M1320	MiniDIN	MiniDIN	Terminals	Terminals	
M1321	MiniDIN	MiniDIN	Terminals	Terminals	Barometric pressure
M1322	MiniDIN	MiniDIN	Terminals	Terminals	CO ₂
M1323	MiniDIN	MiniDIN	Terminals	Terminals	Barometric pressure, CO ₂
M1300	Terminals	Terminals	Terminals	Terminals	
M1440	Ext. probe of CO ₂	MiniDIN	MiniDIN	MiniDIN	

* The Multilogger M1200E does not support Ethernet communication. The device is supplied with alkaline batteries without an AC adapter.

Specification of internal sensors

Internal barometric pressure sensor

Range	600 hPa to 1100 hPa
Accuracy	± 1.3 hPa at 23 °C

Capable of conversion to sea-level pressure.

Internal CO₂ concentration sensor

Range	0 to 2000 ppm*
Accuracy	± (50 ppm + 2% of MV) at 23 °C and 1013 hPa

* Custom range 10 000 ppm.

ALARM output

Output can be used when an alarm is indicated, such as an external buzzer, telephone dialer etc.

Type of output	open collector transistor
Max. switching current	100 mA
Max. voltage on output	12 V
Auxiliary voltage at terminal	+5 V (only when the mains supply is present)

Specification of inputs

Input MiniDIN allows connection of:

- temperature probes Pt1000 with built-in configuration memory (serie xxx/M)

Range	-200 to 600 °C
Accuracy	±0.2 °C up to 100 °C and ±0.2 %MV above 100 °C (without probe)

Type of probe	DigiS/M	DigiL/M
Temperature measurement range	-10 to 60 °C	-30 to 105 °C
Temperature measurement accuracy	± 0.4 °C	± 0.4 °C
Relative humidity measurement range (without condensation)	0 to 95 %RH	0 to 100 %RH
Relative humidity measurement accuracy	± 2.5 %RH	± 2.5 %RH

The probes are supplied with a calibration certificate and are offered in a short version with connector for direct connection to a device or with cable lengths of 1, 2, 5, 10, 15 metres.

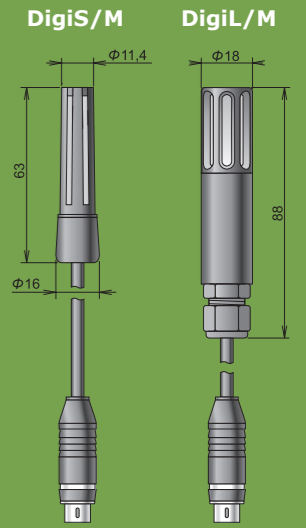

Thermocouple input allows connection of:

- thermocouple probes (J, K, S, B, T, N)

Type of thermocouple	K	J	S	B	T	N
Range	-200 to 1300 °C	-200 to 750 °C	-200 to 1700 °C	-100 to 1800 °C	-200 to 400 °C	-200 to 1300 °C
Accuracy	±(3 % of MV +1.5 °C)	±(3 % of MV +1.5 °C)	±(3 % of MV +1.5 °C)	±(3 % of MV +1 °C)	±(3 % of MV +1.5 °C)	±(3 % of MV +1.5 °C)

- direct input of bipolar voltages with range up to -60 to +140mV

Sensors with voltage input	
Range	-60 to 140 mV -18 to 18 mV
Accuracy	± 100 uV ± 20 uV

Removable terminal block allows connection of:

- sensors with voltage output

Range	0 V to 10 V
Accuracy	± 10 mV

Range	0 mA to 20 mA
Accuracy	± 20 uA

- two-state signal

Two state signals may only be applied to input 3 and 4.

Potential-less contact
Voltage signal 0 - 30 V

- pulse signal

The pulse signal may only be applied to input 4.

External CO₂ probe for M1440

- external probe SN220

Range	0 to 10000 ppm
Accuracy	± (110 ppm + 2 % of MV) at 23 °C and 1013 hPa

- external probe SN253

Range	0 to 50000 ppm
Accuracy	± (110 ppm + 2 % of MV) at 23 °C and 1013 hPa

Cable extensions of 1, 2 and 4 meters can be purchased for the probes.

MULTILOGGER

Celibrated universal 16-channel datalogger with Ethernet interface



The COMET System, s.r.o. company is continuously developing and improving its product. COMET System, s.r.o. reserves the right to carry out technical changes in equipment or product without any previous notice.