

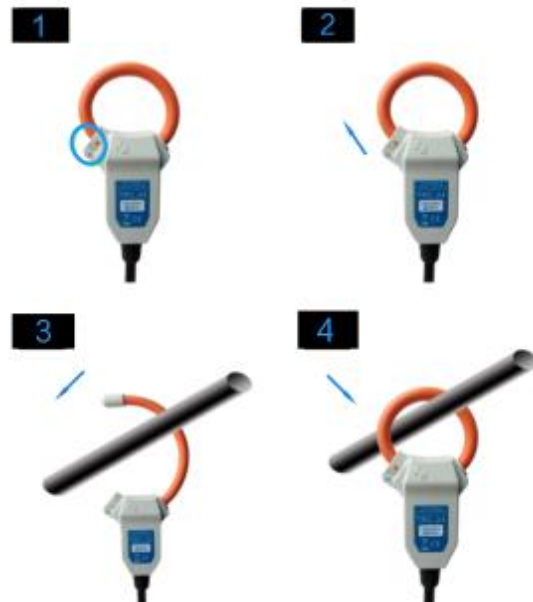

How to use



TRC

Ø6 Flexible Rogowski coil

- High linearity from 1A to 1000A
- Wide dynamic range
- Very useful with large size or awkward shaped conductors or in places with limited access
- No danger from open-circuited secondary
- Not damaged by large overloads
- Non-intrusive, no power drawn from the main
- Measurement uniformity at any position of the conductor inside the coil
- Excellent degree of rejection to the external current conductor

Feature

TRC is a MINI flexible current transducer based on Rogowski principle, particularly suitable for measurement in combination with portable devices. MRC coils are available in different sizes and can be supplied according to customer's design, therefore they can be used in all those applications, in which traditional transducers are not fitting due to its size and/or weight.

Due to its specific features, flexible Rogowski coil is an extremely comfortable solution for current measurement and can be used in a number of cases where traditional current transducer is not the adequate solution.

MRC coil is provided with a shield against the influence of external magnetic fields, therefore it grants a stable measurement from low currents to hundreds of kA. The Rogowski coils must be connected to an electronic integrator

for 90° phase shift compensation and frequency equalization. Our DIN-RAIL and panel meters can interface Rogowski coils directly without the need of the external integrators. This is an advantage because there is no external boxes or

any power supply with consequent ease of use. The particular features of the Rogowski coils combined with the extremely flexible input programming of our portable meters, allow to carry out measurement by all applications.

Advantage

- Calibrated to 0.5%
- 6mm section make more stable
- Easy to fixed on bus-bar or cable by cable ties
- Very competitive price

Related Products

S1 D1 S9 SW A01 A05 ME631 ME432

Applications

- Measuring devices, lab instrumentation
- Power monitoring & control systems
- DC ripple measurement
- Harmonics and transients monitoring
- Power meter, Power analyzer sensor

What is a Rogowski coil?

Rogowski coils have been used for the detection and measurement of electric currents for decades. They are based on a simple principle: an “air-cored” coil is placed around the conductor in a toroidal fashion and the magnetic field produced by the current induces a voltage in the coil. The voltage output is proportional to the rate of change of current. This voltage is integrated, thus producing an output proportional to the current.

By using precision winding techniques, especially developed for the purpose, the coils are manufactured so that their output is not influenced by the position of the conductor within the toroid, and to reject interference from external magnetic fields caused, for example, from nearby conductors. Basically, a Rogowski coil current measuring system consists of a combination of a coil and conditioning electronics. Rogowski coil current transducers are used for the AC measurement.

They can be used in similar circumstances to current transformers but for many applications they have considerable advantages:

- Wide dynamic range.
- High linearity.
- Very useful with large size or awkward shaped conductors or in places with limited access. Thanks to the structure without hard core, the coil can be easily manufactured according to the application or to the available space.
- Unlike traditional current transducers, there is no danger from open-circuited secondaries.
- They cannot be damaged by large overloads.
- They are non-intrusive. They draw no power from the main circuit carrying the current to be measured.
- They are also light weighted and in some applications are light enough to be suspended on the conductor being measured.

The transducer does not measure direct currents but, unlike a current transformer, it can carry out accurate measurements of AC component even if there is a large superimposed DC component, since there is no iron core causing saturation. This feature is particularly useful for measuring ripple currents for example in battery charging systems.

| MODEL | TRC-16 | TRC-24 | TRC-36 |
|--|---|---------------------------|--------|
| Coil length | 80mm | 97mm | 130mm |
| Window size | 16mm | 24mm | 36mm |
| Reference Rated current | 100A | 300A | 600A |
| Weight | Approx 80-100g | | |
| Coil Resistance | from 100 to 300 Ω | | |
| Maximum current measurable | 100kA | | |
| Coil Section | 6mm | | |
| Lead length | 2meter | | |
| Output (di/dt) | Uncalibrated | 60mV/kA@50Hz 72mV/kA@60Hz | |
| | Calibrated | 50mV/kA@50Hz 60mV/kA@60Hz | |
| Read Accuracy | Calibrated <0.5% (central position, 25°C) Uncalibrated < 5% tolerance (central position, 25°C) | | |
| Temperature | Uncalibrated 200ppm/C | | |
| | Calibrated 300ppm/C | | |
| Position Error | ± 1% maximum | | |
| Output on 0A (zero drift) | ≤0.05mV | | |
| Phase error | ≤0.5° | | |
| Linearity | ±0.2% of reading | | |
| Bandwidth | 1Hz to 100kHz(-3dB) | | |
| Operating temperature | -30°C to 80°C | | |
| Storage temperature | -40°C to 90°C | | |
| Other requirements, please contact us to OEM. | | | |

Specification



Position sensitivity

| Conductor Position | Typical Error(%) |
|----------------------------------|------------------|
| ● Adjacent to the center of coil | <0.5% |
| ● Adjacent to the inside coil | <1% |

Materials

| | |
|--------------|---|
| Coil & cable | Thermoplastic rubber flame retardant UL 94 V-0 rated |
| Couplings | PA6 UL 94 V-O rated |
| Color(coil) | Black, Yellow, Red, Green, Blue |
| Shielded | 100% coil, 100% output cable |

Safety

| | |
|--------------------|---|
| Certifications | CE marked |
| | Complies with LVD EN 61010-1:2010 EMC EN 61326-1:2013 |
| | IP68 |
| Voltage insulation | Coil: 1000V |
| | Signal cable:1000V |
| Safety | 1000V CATIII ,600V CATIV |

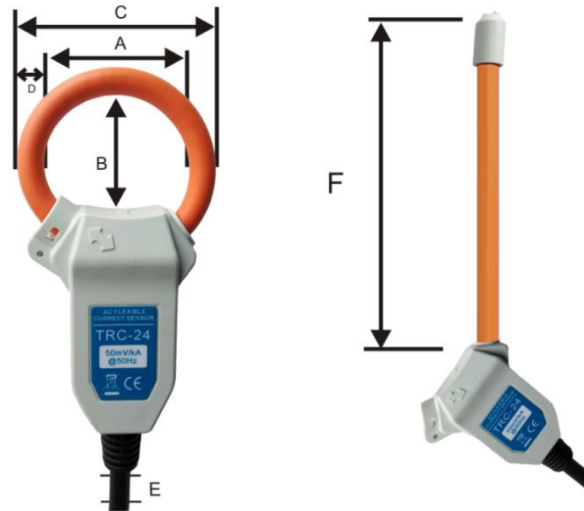
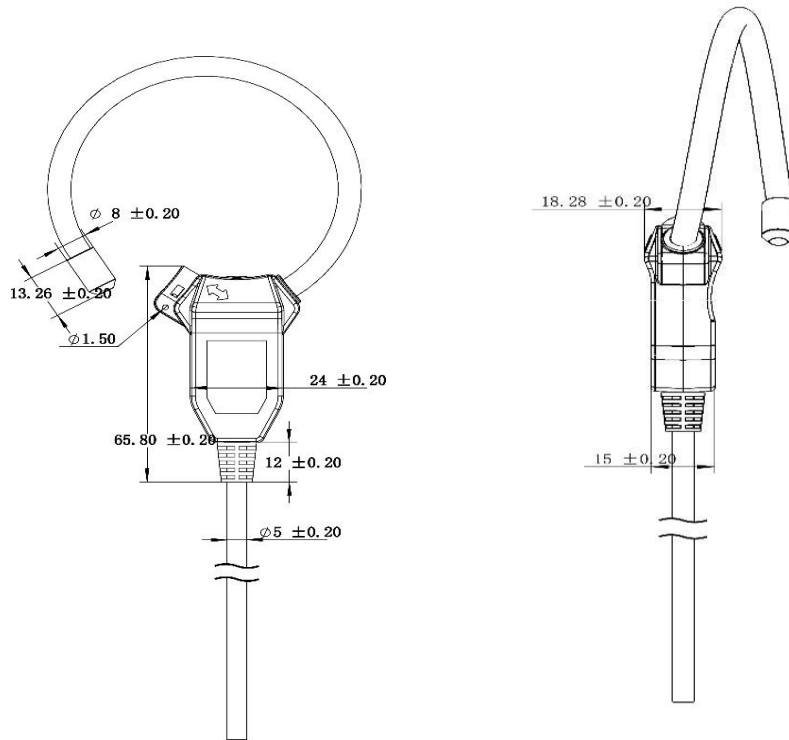

Dimensions tolerance:

A,B,C,F: ± 1mm, D: ± 0.2mm, E: ± 10mm

| Dimensions(mm) | TRC-16 | TRC-24 | TRC-36 |
|---------------------------|--------|--------|--------|
| A.Windows size A | 22 | 27.5 | 36 |
| B.Windows size B | 16 | 24 | 37 |
| C.Coil O.D. | 34 | 39.5 | 48 |
| D.Coil section | | 6 | |
| E.Lead Cable Total Length | | 2000 | |
| F:Coil length | 80 | 97 | 130 |

Safety and warning notes

In order to guarantee safe operation of the transducer and to be able to make proper use of all features and functions, please read these instructions thoroughly! Safe operation can only be guaranteed if the transducer is used for the purpose it has been designed for and within the limits of the technical specifications. Ensure you get up-to-date technical information that can be found in the latest associated datasheet under www.rogowski.cn

Caution! Risk of danger

Ignoring the warnings can lead to serious injury and/or cause damage!

The electric measuring transducer may only be installed and put into operation by qualified personnel that have received an appropriate training. The corresponding national regulations shall be observed during installation and operation of the transducer and any electrical conductor. The transducer shall be used in electric/electronic equipment the respect to applicable standards and safety requirements and in accordance with all the related systems and components manufacturers' operating instructions.

Caution! Risk of electrical shock

When operating the transducer, certain parts of the module may carry hazardous live voltage (e.g. primary conductor). The user shall ensure to take all measures necessary to protect against electrical shock. The transducer is a build-in device containing conducting parts that shall not be accessible after installation. A protective enclosure or additional insulation barrier may be necessary. Installation and maintenance shall be done with the main power supply disconnected except if there are no hazardous live parts in or in close proximity to the system and if the applicable national regulations are fully observed.

Safe and trouble-free operation of this transducer can only be guaranteed if transport, storage and installation are carried out correctly and operation and maintenance are carried out with care.

WARNING!

Do not stress the coil by applying any kind of mechanical force (ie. twisting, puncturing, excessive pressure, tight bending, etc.) which will dramatically degrade the device's accuracy.

Order code

Coil:

| Coil Model | Coil diameter (mm) | Output ratio and tolerance | Signal cable length |
|--------------------------------|---|--|--|
| Code:Y-FCT | Code:200(Typical rated 500A) Code:350(Typical rated 1500A) Code:510(Typical rated 3kA) Code:800(Typical rated 10kA) Y-FCT code is length. | Code:110 110mV/kA@50Hz±5% Code:100 100mV/kA@50Hz±0.5% Code:85 | Code:-2m Code:-5m Code:-10m Code:-20m |
| | Code:NRC | 85mV/kA@50Hz±0.5% Code:50 50mV/kA@50Hz±0.5% | |
| Code:MRC | Code:16(Typical rated 100A) Code:24(Typical rated 300A) Code:36(Typical rated 600A) | Code:60 60mV/kA@50Hz±5% Code:50 50mV/kA@50Hz±0.5% | |
| Code:SRC | Code:50 Code:100 Code:150 | Code:360 360mV/kA@50Hz±5% Code:333 333mV/kA@50Hz±0.5% Code:100 100mV/kA@50Hz±0.5% Code:85 85mV/kA@50Hz±0.5% Code:50 50mV/kA@50Hz±0.5% | |
| Other requirement could be OEM | | | |

Final Code=Coil model+Coil length(MRC NRC is diameter)+Output ratio tolerance+Signal cable length

For example:

Y-FCT-350-100-2m is Y shape connector,coil length 350mm,output 100mV/kA@50Hz 0.5% tolerance,signal cable length is 2meter.

Integrator:

| Integrator | Output form | Output value | Rated current | Power supply |
|---|-----------------------------|--------------------------------|---|--|
| Code:D1 (DIN-RAIL integrator) | Code: .1(AC voltage output) | Code: -333(333mV) | Code: -600A Code: -1kA Code: -3kA Code: -6kA | Code: -12(12V DC) Code: -24(24V DC) |
| | Code: .2(DC voltage output) | Code: -1(1V) Code: -5(5V) | | |
| Code:S9 (mini integrator) | Code: .1(AC voltage output) | Code: -333(333mV) | | Code: -12(6-12V DC) Code: -24(24V DC) |
| | Code: .2(DC voltage output) | Code: -1(1V) Code: -3(3V) | | |
| Code:S1 (high accuracy integrator) | Code: .1(AC voltage output) | Code: -333(333mV) | | Code: -12(4-12V DC) Code: -24(24V DC) |
| | Code: .2(DC voltage output) | Code: -5(5V) Code: -10(10V) | | |
| Code:ATP-01 (1A output three phase integrator) | Code: .3(4-20mA output) | N/A | | Code: -12(12V DC) Code: -24(24V DC) |
| | N/A(0-1A) | N/A | | |
| Code:A01 (1A output integrator) | N/A(0-1A) | N/A | Code: -12(12V DC) Code: -24(24V DC) | |
| | N/A(0-5A) | N/A | | |
| Code:A05 (5A output integrator) | N/A(0-5A) | N/A | Code: -12(12V DC) Code: -24(24V DC) | |
| | N/A(0-10VAC peak) | N/A | | |
| Code:HF (high frequency integrator) | N/A(0-10VAC peak) | N/A | Code: -1kA(1kA/1V) Code: -10kA(10kA/1V) | N/A(4-12V DC) |
| Other requirement could be OEM | | | | |

Final Code=Integrator+Output form+Output value+Rated current+Power supply

For example:

D1.1-1-500A-12 is D1 integrator,AC voltage output,500A rated,output 1V,power supply 12V DC

A01-1kA is A01 integrator,rated 1kA,output 1A,power supply 85-265V AC DC